

Generator Rotating Field

Regulator output connected to generator slip rings.

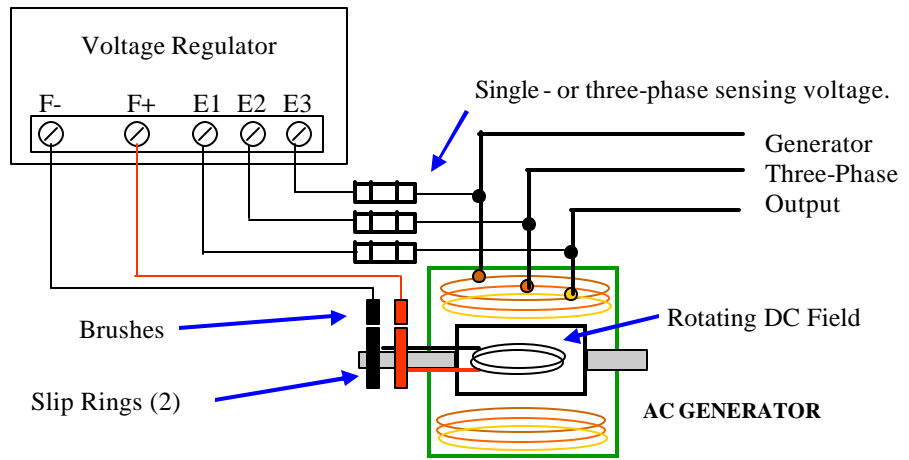

Separate DC Exciter

Regulator output connected to exciter stationary field.

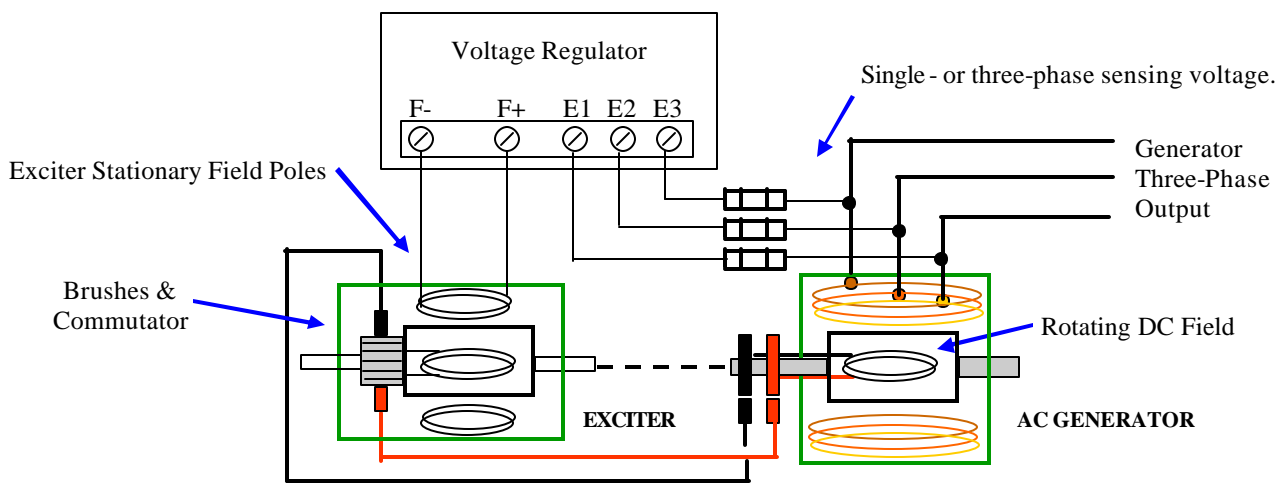

Brushless Excitation

Regulator connected to brushless exciter stationary field.

